

# Introduction to Time-Sensitive Networking

Kehong Huang

2019.9.25



---

Contents

---

What is TSN

---

Compare to Ethernet

---

Standards of TSN

---

Application fields of TSN

---

Some related publications

---

Some Q&A

---

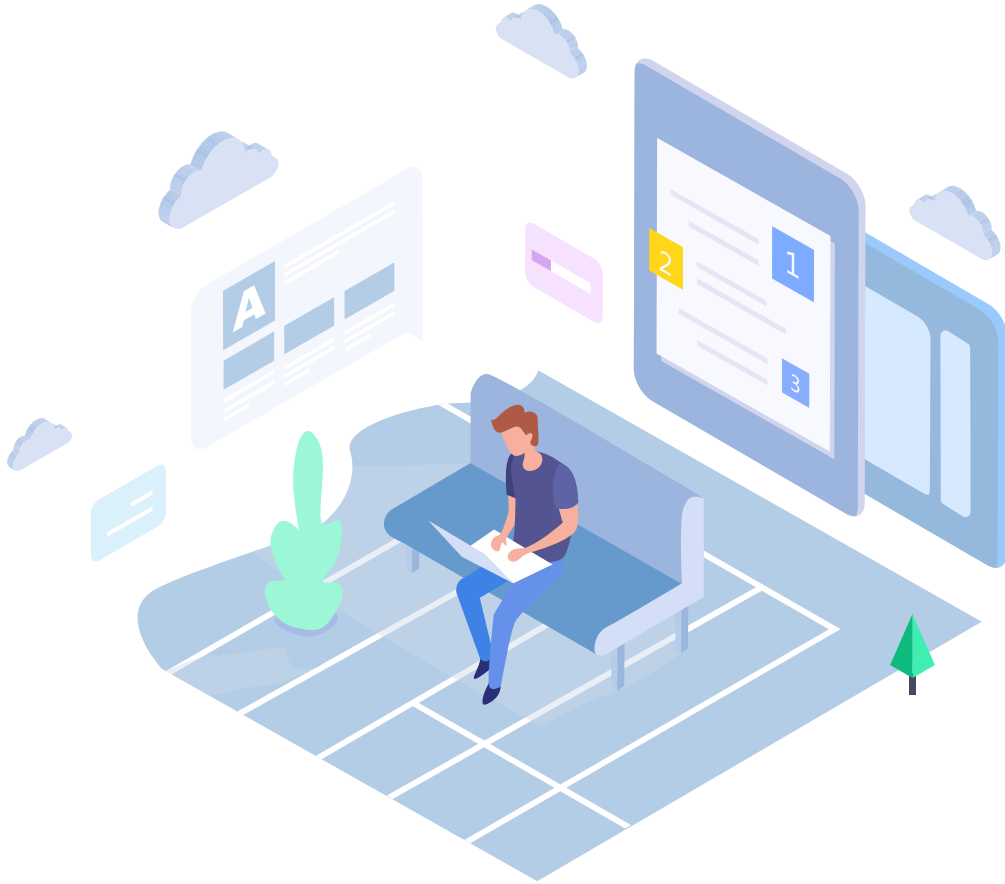

# 1 What is TSN

---

Time-Sensitive Networking(TSN) is an Ethernet extension defined by IEEE.

TSN is designed to make Ethernet-based networks more deterministic.

The consumer and enterprise world of Ethernet and wireless Ethernet communication is bandwidth oriented.

For example, while browsing the Internet you accept a varying amount of delay before video playback starts. Although there is a preference for quick interaction, for the average user it is acceptable if one out of 100 clicks perform an order of magnitude worse.

However, if a video is bad quality or even halted the typical consumer will be frustrated.

## 2 Compare to Ethernet

---

Ethernet is generally thought to have been introduced by Bob Metcalfe in 1973.  
Ethernet technology fundamentally solves the problem of information transmission/sharing in LAN.

When it was created, however, Ethernet considered only static information that was not real-time.  
For example, words and pictures. Even if it is Shared audio and video, it is only available for download and transfer to each other.

Ethernet is the most widely used communication protocol standard in current LAN. Ethernet use CSMA/CD technology, currently commonly used twisted pair network.

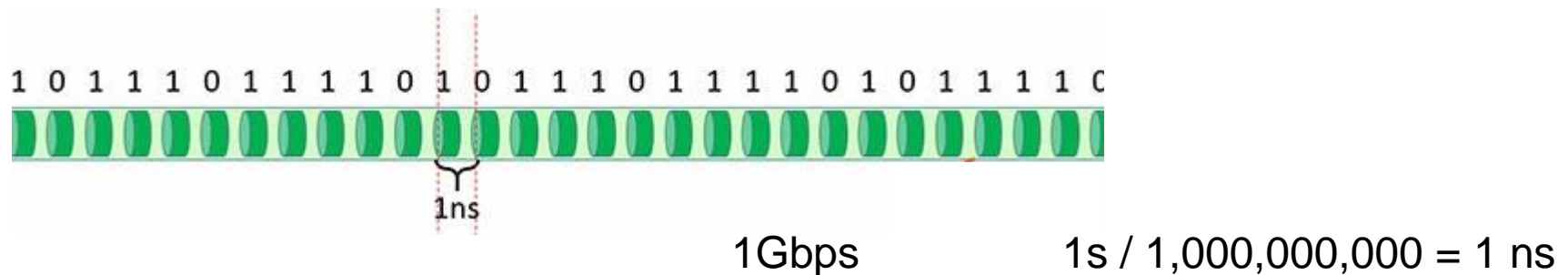

## 2 Compare to Ethernet

---

Ethernet is generally thought to have been introduced by Bob Metcalfe in 1973.  
Ethernet technology fundamentally solves the problem of information transmission/sharing in LAN.

When it was created, however, Ethernet considered only static information that was not real-time.  
For example, words and pictures. Even if it is Shared audio and video, it is only available for download and transfer to each other.

Ethernet is the most widely used communication protocol standard in current LAN. Ethernet use CSMA/CD technology, currently commonly used twisted pair network.

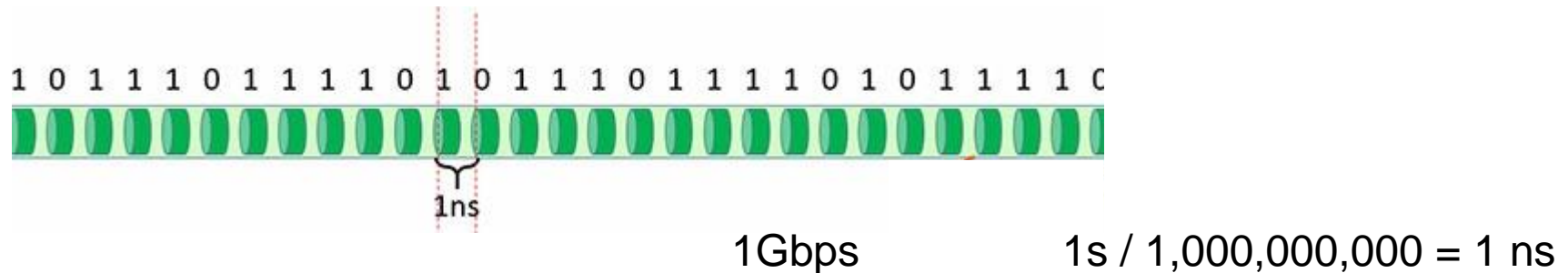

# 2 Compare to Ethernet

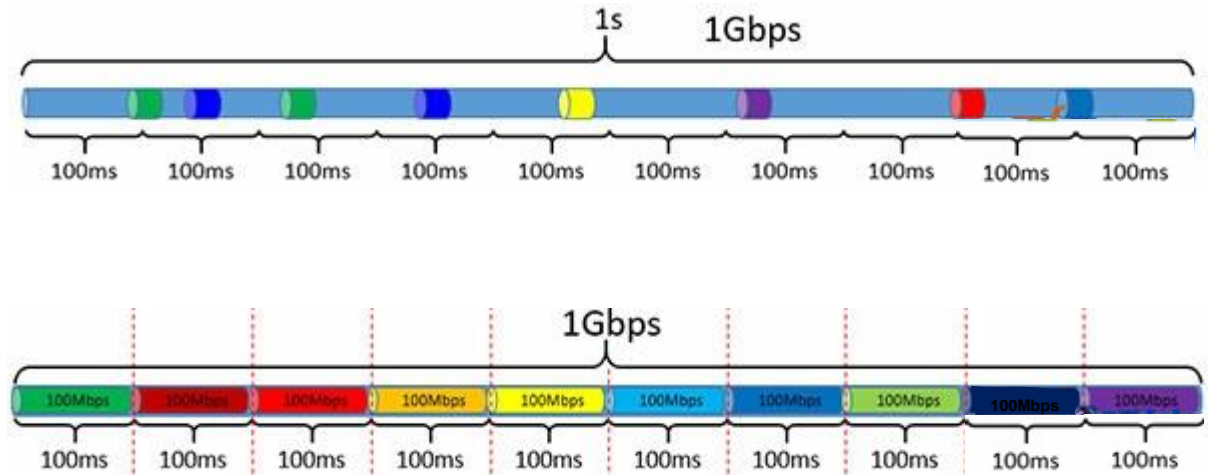
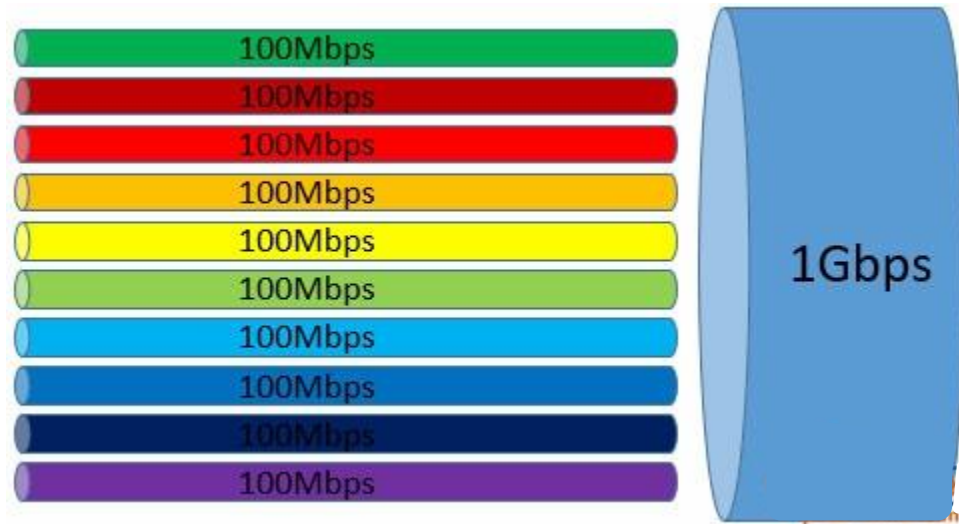

## 2 Compare to Ethernet

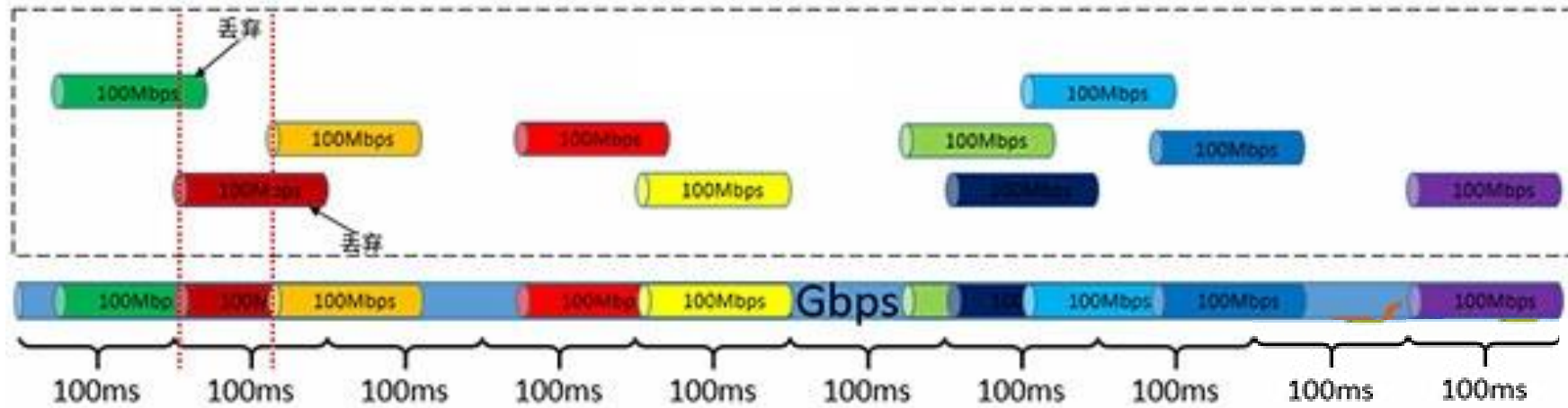

QoS ( Quality of Service )

Best Effort

FIFO

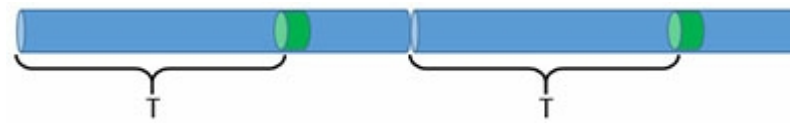
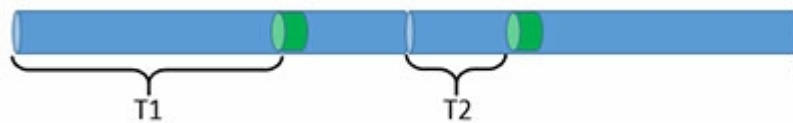

# 2 Compare to Ethernet

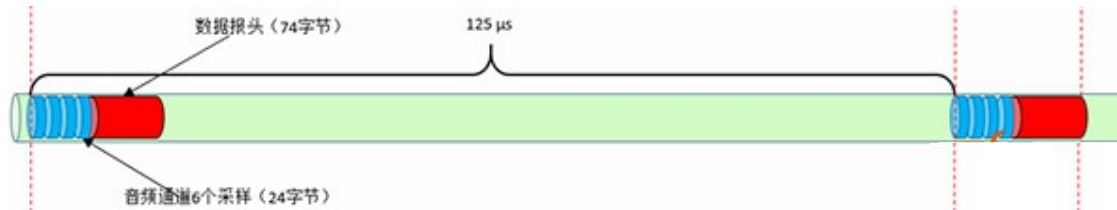

48000Hz  
20.83  $\mu$ s

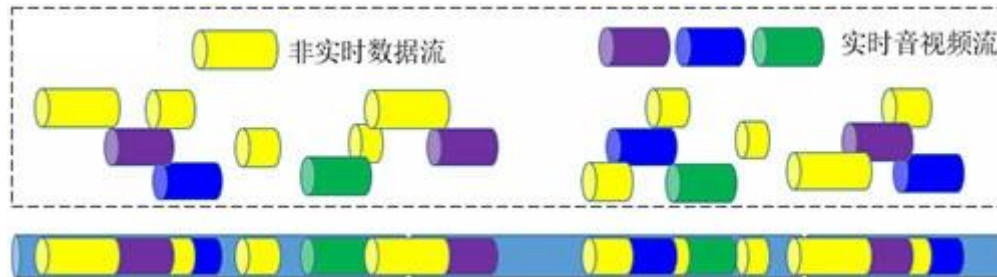

Traffic Shaping  
AVB ( Audio Video Bridging )

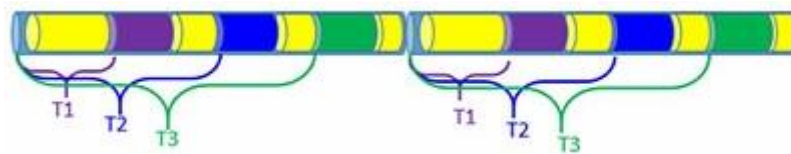

# 3 Standards of TSN



- 802.1AS-Revision
- 802.1Qbv
- 802.1Qbu & 802.3br
- 802.1Qca
- 802.1CB
- ...

Time Synchronization

Scheduling and traffic shaping

Selection of communication paths and fault-tolerance



# 3 Standards of TSN



802.1AS-Revision

**802.1Qbv**

Enhancements to Traffic Scheduling: Time-Aware Shaper

802.1Qbu

802.1Qca

802.1CB

...

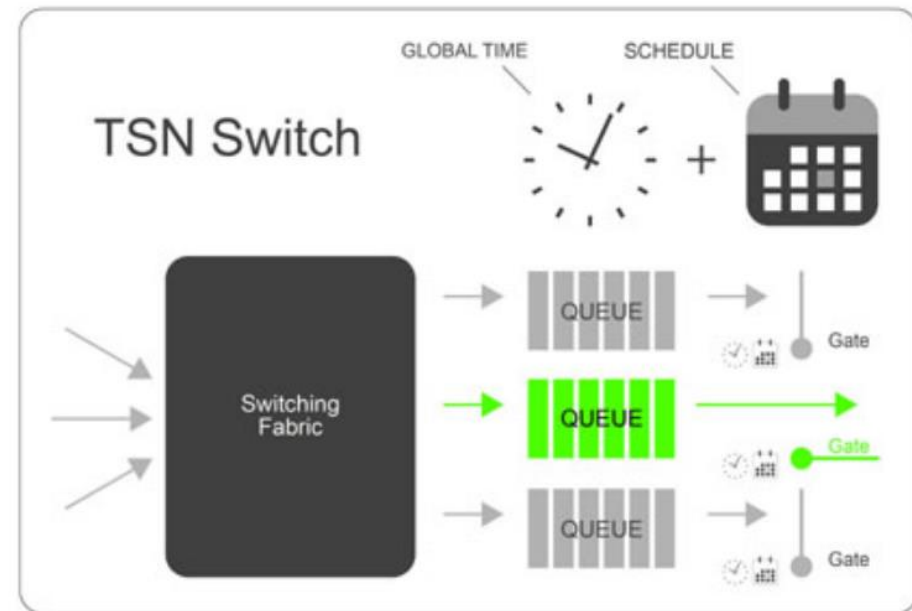

# 3 Standards of TSN



802.1AS-Revision

802.1Qbv

**802.1Qbu & 802.3br**

Frame Preemption and Interspersing Express Traffic (IET)

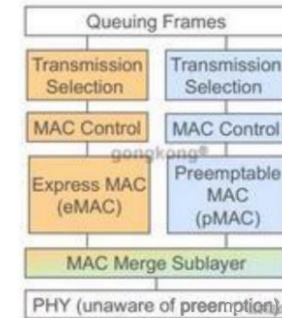
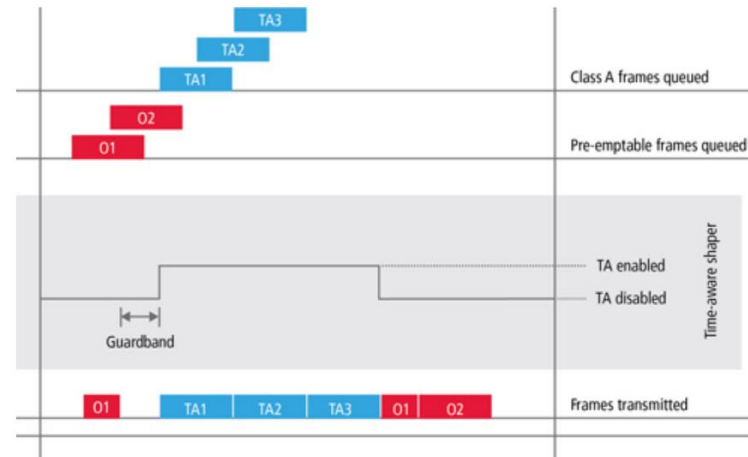

# 3 Standards of TSN



802.1AS-Revision

802.1Qbv

802.1Qbu & 802.3br

802.1Qca

Path Control and Reservation(PCR) specifies extensions to the Intermediate Station to Intermediate Station (IS-IS) protocol to configure multiple paths in bridged networks.

802.1CB

Frame Replication and Elimination for Reliability(FRER) sends duplicate copies of each frame over multiple disjoint paths, to provide proactive seamless redundancy for control applications that cannot tolerate packet losses.

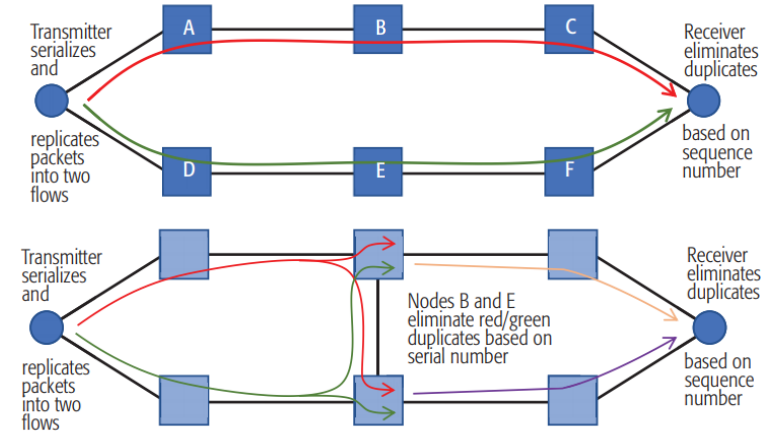

# 4 Application fields of TSN

## PRO AV



- Time Synchronization matters most

## AUTOMOTIVE



- For complicated automotive system, we could manager components with TSN to reduce the cost of Internet and system complexity

## CONSUMER ELECTRONICS



- Link to any device you want and watchin video in real time at home

## INDUSTRIAL



- Most important!
- For any industries that require real-time monitoring or feedback

# 5 Some related publications

Precise  
Sensing  
and  
time s

End-to-  
LIGHT  
and  
segment

	Network segment:			Characteristics						
	FH	FF	DC	Total Network capacity	Latency (excl. propagation)	Jitter	Resource reservation dynamics	Hard Slicing	Guaranteed delivery	Maturity
Standard Ethernet (Section IV-A)	✓	✓	✓	Pb/s	~μs per hop	Unbounded	N/A	No	No	Production
Industrial Ethernet (Section IV-B)	✗	✓	✗	Typ. Gb/s	0.1-100 ms long schedule; sub μs per hop	Tens of ns to μs timescale	Static	Yes	Yes, depending on class of service	Production
TSN (Section IV-C)	✓	✓	✓	Gb/s	Similar to Ethernet	ns timescale (few classes of service)	Static	Limited to few (8 in 802.1Qbv) classes of service per node interface	Yes, depending on class of service	Standardization ongoing, products exist
PON – current (Section IV-D)	✓	✗	✗	~100 Gb/s	~100 μs	N/A	Static (FBA)	Yes (per flow time-wavelength slots allocation)	Yes	Production
OTN / FlexE (Section IV-E)	✓	✗	✗	Tb/s	Dominated by propagation	Nearly jitterless (circuit switching)	Slow (second)	Yes (frame allocation, coarse multi-Gb/s granularity)	Yes	Production
Ethernet / FUSION (Section V-A)	✓	✗	✗	~100 Gb/s	8 μs per hop	10 ns timescale (few classes of service)	N/A	Limited to few classes of service per node interface	Yes	Lab
PON – research (Section V-B)	✓	✗	✗	~100 Gb/s	~10-100 μs	ns timescale	Static (FBA)	Yes (per flow time-wavelength slots allocation)	Yes	Lab
OSS for FH/FF (Section V-C)	✓	✓	✗	Tb/s	ns to μs per hop	ns timescale possible	Fast (sub-second)	Yes (per flow time-wavelength slots allocation)	Yes	Lab
OSS/DC (Section V-C)	✗	✗	✓	Pb/s	ns to μs per hop	ns timescale possible	Fast (sub-second)	Yes (per flow time-wavelength slots allocation)	Yes	Lab
DDN (Section V-D)	End-to-end (FH/FF: OE; DC: CBOSS)			Designed for 1.6 Tb/s per bus (OE); Pb/s in torus configuration (CBOSS)	1-100 μs timescale	ns timescale	Fast (ms-timescale)	Yes (per flow time-wavelength slots allocation)	Yes	Lab

e

ed

## 5 Some related publications

---

### **IEEE Communications Standards Magazine ( 2018 )**

#### **Introduction to Time-Sensitive Networking**

explains how TSN differs from other types of packet services and describes in detail the essential features of TSN. The article also lists use cases for TSN and collects the relevant standards.

#### **Time-Sensitive Networking: An Introduction**

describes the tools in the TSN toolset and explains in detail the TSN standards to provide bounded low latency and zero congestion loss. Furthermore, the article looks out to gaps and next steps in TSN standardization

#### **Distributing Deterministic, Accurate Time for Tightly Coordinated Network and Software Applications: IEEE 802.1AS, the TSN profile of PTP: Concepts and Applications**

provides a description of TSN time synchronization standard and details on time transfer on Ethernet links and Wireless LANs

## 5 Some related publications

---

### **IEEE Communications Standards Magazine ( 2018 )**

#### **Traffic Planning for Time-Sensitive Communication**

describes 802.1Qbv compared to other time-based transmission and queuing techniques and also describes how to provide a schedule for a given traffic pattern supported by a particular network.

### **Level 5 by Layer 2: Time-Sensitive Networking for Autonomous Vehicles**

describes the essential TSN features for automotive networks and the application details of key TSN standards to the automotive use case in light of the needs of autonomous driving

### **Enabling Fog Computing for Industrial Automation through Time-Sensitive Networking (TSN)**

involves higher-layer aspects such as network configuration and fog computing to leverage TSN for industrial automation. And explains how fog computing can be applied together with TSN.

# 6 Some Q&A



## How can we implement a TSN system?

TSN is a VLAN, so we need the switch to deal with the time synchronization and scheduling, for controller, we need the specific chips to support it.



## What's the strength for TSN compared to the existed technologies

TSN is in the layer 2 of the OSI network architecture, so it can combine a lot of technologies like OPC UA to achieve better performance.



## What does it mean to our projects?

For edge computing, it can certainly provide low data transmission latency. We use model compression or segmentation because the large transmission latency. And we can think about a more complicated application scenarios, like many monitors linked to the same edge device , therefore we could use it to control the data transmission.

But it will also be difficult to proficiently use various kinds of standards.

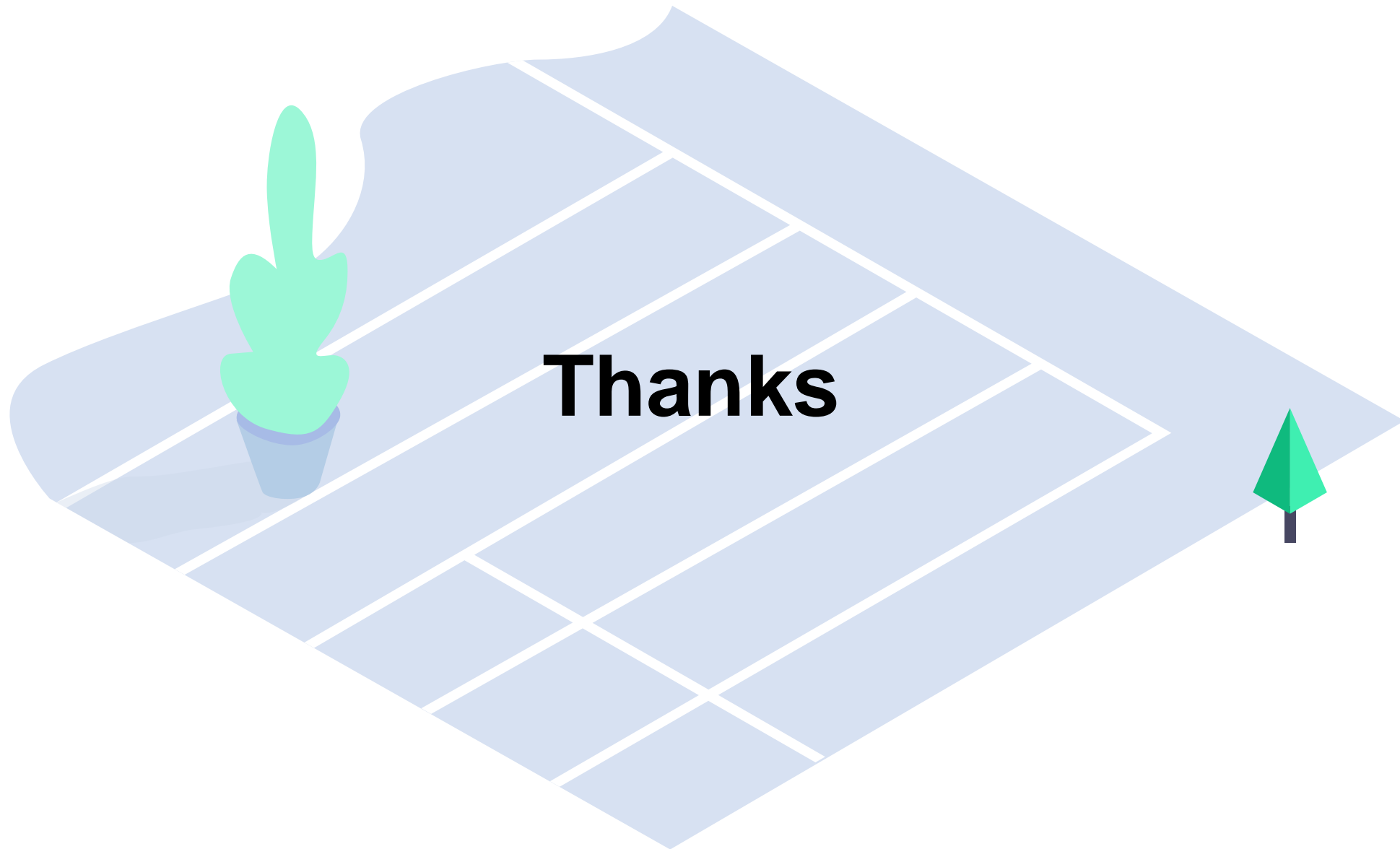

**Thanks**